



**Powerful Electrical Solutions
in the Oil & Gas Industry**



Converteam – a world leader in electrical solutions

Converteam is an engineered solutions and system provider. Specialist of power conversion, we convert power from mechanical to electrical or vice versa, and from electrical to electrical. These solutions are built around three core components: electrical machines, variable speed drives, automation and process controls. Our scope covers system design, manufacturing, system integration, installation, commissioning and a broad range of services. Our worldwide 5,000 skilled staff members remain fully committed to one overriding goal: to bring you the best in technology, backing this up with a truly effective service in all markets. Our expertise encompasses marine, oil & gas and offshore, power generation, renewable energy, industry, and more.

Electrical Solutions for the complete process

Converteam is your partner to power your business

Based on its proven expertise and experience, Converteam offers complete electrical reliable solutions throughout the value chain from upstream to downstream. Our customers include all the main oil, gas and petrochemical companies and many national companies in different countries worldwide.

The solutions designed by Converteam are based on Variable Speed Drive Systems (VSDS). We provide complete systems to drive compressors, pumps, extruders and fans, from the network to the electric motor shaft-end. With more than 30 years' experience, our proven VSDS solution uses high performance drive converters connected to synchronous or induction motors. We are a key supplier for all gas compression applications for transport, storage, gas re-injection and gas liquefaction. We are also the leader in high-speed electrical solutions (up to 20,000rpm) able to drive compressors up to 25MW.

Always at the cutting edge of technology, Converteam developed a gas compression system dedicated to exploitation at great depths.



Upstream:

- Oil & gas production
- Enhanced oil recovery
- Gas liquefaction
- Subsea applications

Midstream:

- Oil & gas transportation
- Gas storage

Downstream:

- Petrochemical LDPE (Low Density Polyethylene)
- Petrochemical HDPE (High Density Polyethylene)
- Steam-cracking

The electrical package of the subsea compression station mainly consists of circuit breaker modules, pressure compensated power transformers, variable speed drives and high-speed motors cooled by processed gas. In addition, the control system is designed to control and regulate the subsea compression system, including an uninterruptible power supply system for critical loads.

For the Norwegian gas field known as Ormen Lange situated 120km offshore and some 1000m under the sea level, Converteam is the sole electrical supplier of the 12.5MW system that includes a high-speed motor, two variable speed drives, two uninterruptible power supply units and a massive circuit breaker. For this equipment, virtually inaccessible for routine maintenance and repair, reliable design and quality of manufacture are paramount.

Electrical Solutions from Network to Shaft-end

Variable Speed Drive Systems (VSIDS) step-by-step

Converteam's electrical solution is based on Variable Speed Drive Systems (VSIDS). It is a complete system from network to shaft-end, essentially comprised of:

- transformer
- frequency converter
- electric motor
- auxiliaries

- Network analysis
- Calculation of harmonic filters
- Sizing transformer, variable speed drives, motors
- Dynamic studies
- Torsional analysis

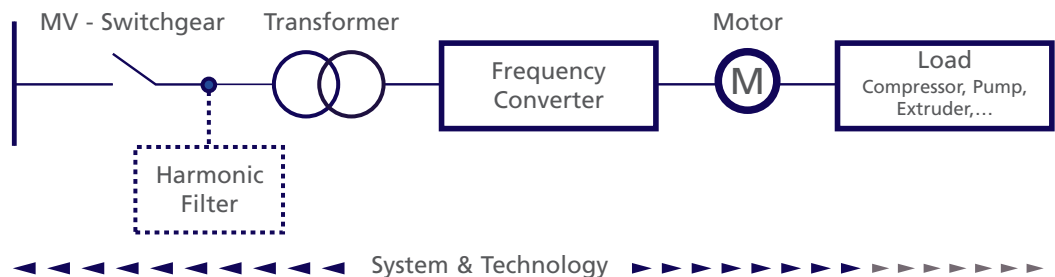

MV-Switchgear

Harmonic Filter

Frequency Converter

Compressor / Motor

From the Network

The frequency converter and transformer are commonly designed to minimize disturbances to the power network. If required, harmonic attenuation of the system with filters is added.

Going through the Frequency Converter

Thanks to the use of high voltage semiconductor devices in inverters, all standard medium voltages are available with a range of frequency converter from a few megawatts to more than 100MW. A drive power of up to 6MW can be implemented with air-cooled versions; more powerful applications require water cooling.

The fully digital controller is a state-of-the-art power electronics controller (PEC) featuring vector control. It incorporates a monitoring system which ensures maximum protection and immediate recognition of irregular conditions.

To the Electric Motor

Converteam has more than a century's experience in the design and manufacture of medium and high voltage AC motors. Our range of machinery includes all types of electric motors:

- Induction conventional speed
- Induction high-speed
- Synchronous
- Explosion-proof.

Technical Expertise for the benefits of all Customers

Converteam is your single source supplier with single source responsibility

Converteam offers the unique benefit of a fully integrated package of electrical power and control systems supplied from one reliable source. Converteam's project management helps coordinate and integrate all associated equipment according to the individual project or customer's need, in compliance with global standards.

Customized technology

Converteam analyzes the project requirements in close cooperation with the customer and suggests optimized solutions. Converteam's specialist teams bring their expertise to ensure optimum process performance in compliance with international standards for electrical equipment.



Single source of supply

Converteam assigns a dedicated management team to every project through all phases from the first design to final installation. We design, supply and integrate the different electrical components and perform routine tests on our factory premises. On

A long-term partnership

Converteam's strategy is to develop interactive relationships based on a long-term commitment policy:

- defining the right technical solution offering optimum benefits to its customers
- being open to new solutions and methods with no compromise on reliability or safety
- providing efficient and high quality services
- doing business in an ethical manner.

request, in coordination with the OEM, combined and / or string tests can be carried out.

Afterwards, many on-site services such as installation and commissioning can be provided on request.

After sales service is an essential part of Converteam's offering to its customers

Through our network of regional business centers, a highly qualified and experienced team is able to offer customized services such as spares supply, repairs and refurbishment, remote diagnostic, planned maintenance, technical support, obsolescence management and training.



- Solutions dedicated to oil & gas and petrochemicals
- Technical expertise
- Customized technology
- Single source of supply and single source responsibility
- Dedicated 24/7 customer service worldwide
- Long-term partnership

Converteam scope

- Consulting
- Manufacturing
- System integration
- Installation
- Commissioning
- 24/7 customer service

Variable Speed Drive Solutions with PWM Inverters Technology

MV7000 Drive Systems 1 up to 48MW

The MV7000 high performance medium voltage drive offers outstanding performance and excellent reliability with a very compact design. Based on powerful press-pack IGBTs, the MV7000 medium voltage drive often eliminates requirements for filters and never requires power factor correction. Associated with our range of high-speed motors (MGV), the MV7000 drive is particularly adapted to gearless applications for gas compression.

MV7000 capabilities:

- Up to 48MW
- Induction and synchronous motors
- All speed ranges

Particularly adapted to:

- Gas transportation and storage
- Refinery processes
- HDPE, LDPE units
- Subsea applications
- Soft starting of high power motors



In the factory



PECe

Power Electronic Controller

The MV7000 drive is modular and features different options, such as regenerative front ends and connection to a DC bus. The MV7000 is either water or air cooled. This drive is suitable for induction motors but also for synchronous motors with dedicated high performance vector control, in all speed ranges from low-speed reciprocating to high-speed centrifugal compressor drives. The MV7000 drive family covers the medium and high power range up to 48MW at motor voltages of 3.3, 4.16, 6.6 and 9.9kV.

The latest generation of press-pack IGBTs with more active power and lower losses places the MV7000 drive as world class in terms of reliability, efficiency and power density. It is a PWM 3-level inverter providing:

- excellent output waveforms
- very low motor current harmonics
- operation at very low frequency, full torque or operation at high frequency up to 300Hz.

Variable Speed Drive Solutions with LCI Technology

SD7000 Drive Systems up to 100MW

Based on synchronous motor and thyristor technology, SD7000 is the mature and proven solution dedicated to high power. This Load Commuted Inverter (LCI) is ideally suited to controlling high-power loads, such as large compressors. Like the MV7000, this technology offers a very high availability and reliability level for continuous operation 365 days a year, with maintenance every six years, and brings operational flexibility.



SD7000 capabilities:

- Up to 100MW
- Synchronous motors
- Four-quadrant operation

This solution suits the control of large powers:

- Gas injection
- LNG plants
- Gas transportation (large pipelines)
- Steam-crackers
- Soft starting of high power motors

The SD7000 is a Load Commuted Inverter (LCI) divided into three main parts:

- the thyristor rectifier bridge, known as the “network bridge”
- the thyristor inverter bridge, known as the “machine bridge”, and
- an intermediate DC circuit, whose reactor ensures decoupling between the network and the machine bridges.

The SD7000 drive is modular. Our range covers a large choice from 3.1kV to 13.8kV and from 10MW to 100MW. In addition, Convertteam’s comprehensive expertise in power electronics ensures optimum matching to our customers’ requirements.

With its four-quadrant operation, the SD7000 offers many advantages:

- stable operation at all intermediate speeds in all speed ranges
- energy regeneration onto the network
- high starting torque
- constant torque maintained throughout the speed range
- very high upper power limit.

Motors for all types of Pumps or Compressors

Variable or fixed speed

Converteam has over 100 years' experience in providing motors for all applications, from offshore platforms to harsh desert environments.

For all types of pumps or compressors, whatever the application required, fixed or variable speed, Converteam offers a wide range of electric motors:

- induction or synchronous
- conventional or high-speed
- all types of cooling systems
- conventional or for use within hazardous area
- ATEX certified for hazardous area.

- Squirrel cage induction motors have a simpler construction and are inherently more robust. Up to 20MW, they are the first choice.
- Synchronous motors are generally dedicated to high power.

| Motor range | Power | Motor type | Speed | Voltage |
|-------------|-------------|-----------------------------------|--------------------|--------------|
| F3 | Up to 3MW | Induction motor | Up to 3,600rpm | Up to 13.8kV |
| N3 | Up to 40MW | Induction motor | Up to 3,600rpm | Up to 20kV |
| AKG | Up to 1.6MW | Induction motor Flameproof | Up to 3,600rpm | Up to 11kV |
| ATG | Up to 5.5MW | Induction motor Flameproof | Up to 3,600rpm | Up to 11kV |
| NGV | Up to 30MW | Induction motor High-Speed | Up to 7,000rpm | Up to 6.6kV |
| MGV | Up to 25MW | High-Speed | 6,000 to 20,000rpm | Up to 6.6kV |
| S3 | Up to 15MW | Synchronous motor | Up to 1,800rpm | Up to 13.8kV |
| MS | Up to 40MW | Synchronous motor | Up to 1,800rpm | Up to 13.8kV |
| TM | Up to 100MW | 2-pole turbo synchronous motor | 3,000 to 7,000rpm | Up to 10kV |

With high degree of customization, different enclosures are possible. The cooling system can be adapted to the different industrial environments; totally enclosed, fan-cooled, with or without heat exchangers, air-to-air, air-to-water.

According to the range of our motors, some are available with different mounting types; horizontal or vertical and, depending on the orientation, grease-lubricated anti-friction bearings or split-sleeve design bearings are used.



A Drive Solution with superior Efficiency: High-Speed

Unique expertise in high-speed machines

Converteam was the pioneer in the development of high-speed solutions. A series of induction motors have been specially built to meet most demanding requirements of compressor systems in regards to speed and capacity.

Our high-speed drive solution now allows direct connection of an induction motor and compressor, eliminating the need for a gearbox. This gives unrivaled improvement in overall drive system efficiency. With the capability to operate at very high-speed, up to 20,000rpm, the weight and dimensions of the complete unit have been significantly reduced. In addition, the magnetic bearings eliminate the optional oil lubrication systems for motors and compressors, thereby reducing maintenance costs.



Integrated concept

The high-speed induction motor and the compressor are installed inside the same pressurized casing directly connected to the gas pipeline. A portion of the gas is used to cool the motor. No gearbox is required. With magnetic bearings, the installation is completely oil-free.

This arrangement is perfectly suited for gas compression and gas storage stations. The integrated concept is environment friendly, with low noise and emission-free. The replacement of gas turbines by electric motors significantly contributes to the reduction in emissions and therefore is compliant with ever more stringent regulations.

Standalone motor

The high-speed motor offered by Converteam is a two-pole induction motor with squirrel cage and laminated rotor. The cooling medium is generally air, cooled in a closed circuit in an air-to-air or air-to-water heat exchanger.

Lubricated bearings or magnetic bearings can also be used.

Due to high quality design and manufacturing, the high-speed induction motor offers excellent performance, efficiency and power factor as well as high reliability.

This motor is especially suitable for gas or steam turbine substitution.

High-Speed benefits:

- Smaller footprint
- Higher overall efficiency
- No lubrication auxiliaries
- Availability increased
- Noise reduction
- Environmentally friendly

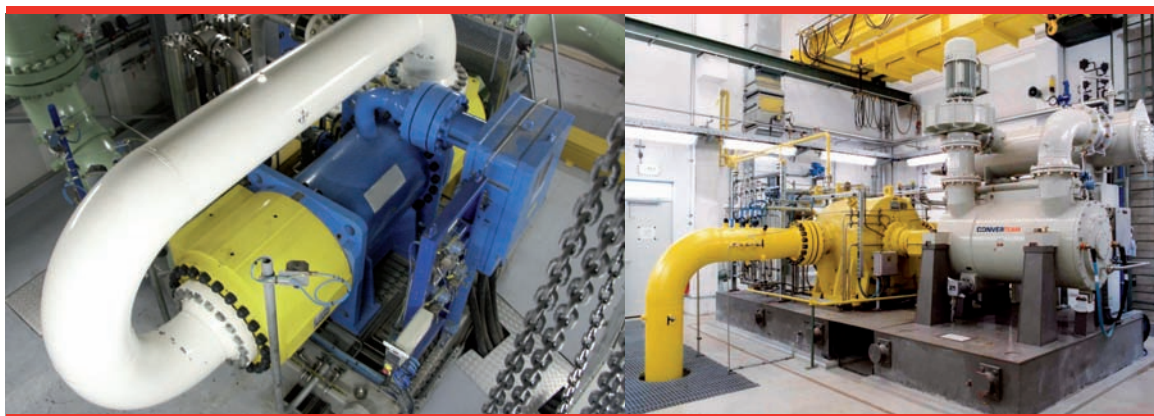

Generators PMS - Power Management System

Converteam's Generators: an extensive experience

Converteam provides generators among the lightest, smallest and most efficient in their class.

Generator capabilities:

- 4 poles; up to 70MVA
- multi-poles; up to 45MVA



Based on our experience of more than 100 years of providing power in over 100 countries where we have over 30,000MW of reliable power installed, we are able to tailor a customized solution to your generator requirements.

From fundamental research & development, through design, manufacture & supply to installation & lifetime support, Converteam provides 4-pole generators for gas and steam turbines and multi-pole generators for diesel and gas engine.

Converteam's reliable and flexible energy management and supervision

Converteam offers a complete automation system designed to provide control over the power network requirements of industrial plants.

Customer benefits:

- Uninterrupted power distribution
- Constant monitoring of source capacities
- Accurate power consumption analysis
- Reduced energy cost
- Reliable solution due to proven technology

The primary purpose of our Power Management System is to manage the vital functions of the electrical system to ensure the maximum availability of power under normal and abnormal circumstances. To help operators analyze and control the electrical system of a plant, our system provides an ergonomic and efficient operator interface. Our Power Management System is designed to communicate with all equipment provided by the different Transmission and Distribution suppliers.

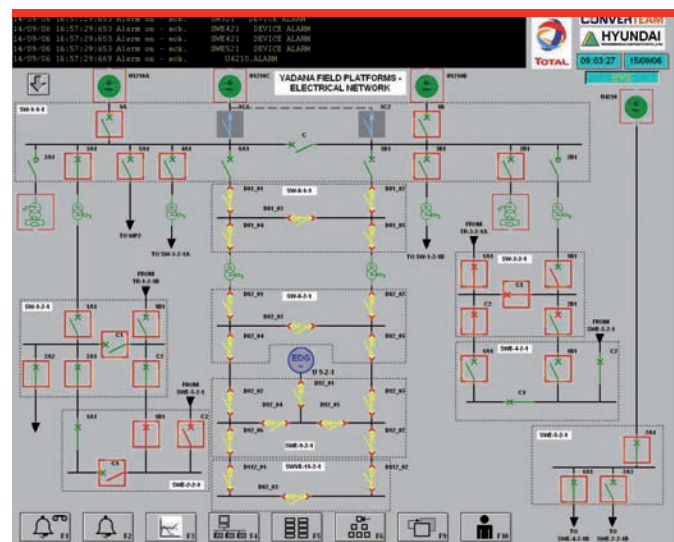

Benefits of the Electrical Solutions for Oil and Gas Applications

Electrical solutions bring more value to Oil & Gas applications

There are many benefits in using an “all-electric drive” instead of a mechanical drive. It is environmentally friendly, both in terms of emissions and efficiency, to use motor drives fed by electrical power produced from a larger power plant. The use of a motor drive eliminates the need for a helper motor or other equipment for starting high power shaft lines. A modern drive converter provides the capability to ride through minor line system disturbances and power interruptions.

The features of the electric motor are: high reliability, high availability and maintainability. In addition, the converter provides process flexibility with no constraints from the 50/60Hz supply frequency.

- Energy saving
- Running at optimum operating points
- Less mechanical stress
- No environmental damage
- Maximum availability of plants



Efficiency and Environmental friendliness

Compared to gas turbines, the variable speed drive system is environmentally friendly:

- Very high efficiency
- Emission free, no pollution
- Low noise level.



Availability and Reliability

Spare parts requirement is very low, maintenance time is very short and mean time to repair is only a few hours.

Because variable speed drives avoid mechanical stress, availability and reliability are increased.



Low CAPEX & OPEX costs

Because of its high availability and reliability with very limited maintenance, OPEX is very low. Total Cost of Ownership makes electrical solutions attractive compared to mechanical solutions.



Headquarters:

Converteam Group SAS
30, avenue Carnot
91345 Massy Cedex, France
Tel: +33 (0)1 64 53 83 00

Offices:**Austria**

Converteam GmbH
Ignaz-Köck-Straße 1
A-1210 Wien
Tel: +43 (0)1 270 70 77-0

Brazil

Converteam Brasil Ltda
Av. Álvares Cabral, 1345
Bairro Lourdes, Belo Horizonte
Minas Gerais, 30170-001
Tel: +55 31 3330 5800

Canada

Converteam Inc.
845 Harrington Court
Burlington, Ontario L7N 3P3
Tel: +1 905 333 3667

China

Converteam Power Conversion Co. Ltd.
29F, Building A, Lane 58,
East Xinjian Road, Minhang District
201100 Shanghai
Tel: +86 21 641 46080-8000

Denmark

Centervej no. 2
6000 Kolding
Denmark
Tel: +45 763 10930

France

Converteam SAS
1, Square John H. Patterson
91345 Massy Cedex
Tel: +33 (0)1 77 31 20 00

Germany

Converteam GmbH
Culemeyerstrasse 1
12277 Berlin
Tel: +49 (0)30 7622 - 0

India

Converteam India Private Ltd.
Unit No 1003, Tower B, 10th Floor
Millennium Plaza, sector 27
Gurgaon, 122 002 Haryana
Tel: +91 124 4220300

Italy

Converteam
Via Solari 6
20144 Milano
Tel: +39 02 3651 0049

Norway

Converteam
Lysaker Torg 45
1326 Lysaker
Tel: +47 67 83 82 50

Russia

Converteam GmbH
Dubininskaya street, 53,
bld. 5, office 212.
115054 Moscow, Russia
Tel.: +7(499) 270 27 11

Singapore

Converteam Ltd, Singapore Branch
331 North Bridge Road #07-05
Odeon Towers
Singapore, 188720
Tel: +65 6332 0940

South Korea

Drives & Controls Services Ltd
Korean Branch
3F, Dong Ju Bldg.
1200-12, Cho Ryang-Dong, Dong-ku
Busan, 601-838
Tel: +82 51 465 9050-1

United Arab Emirates

Converteam SAS
Khalidiya Road
Pearl Plaza Building
P.O. Box: 42536 Abu Dhabi
Tel: +971 2 639 0846

UK

Converteam UK Ltd.
Boughton Road
Rugby, Warwickshire CV21 1BU
Tel: +44 (0)1788 563 563

USA

Converteam Inc.
610 Epsilon Drive
Pittsburgh, PA 15238
Tel: +1 412 967 0765

Converteam Electric Machinery
800 Central Avenue
Minneapolis, MN 55413
Tel: 1 612 378 8000

www.converteam.com