

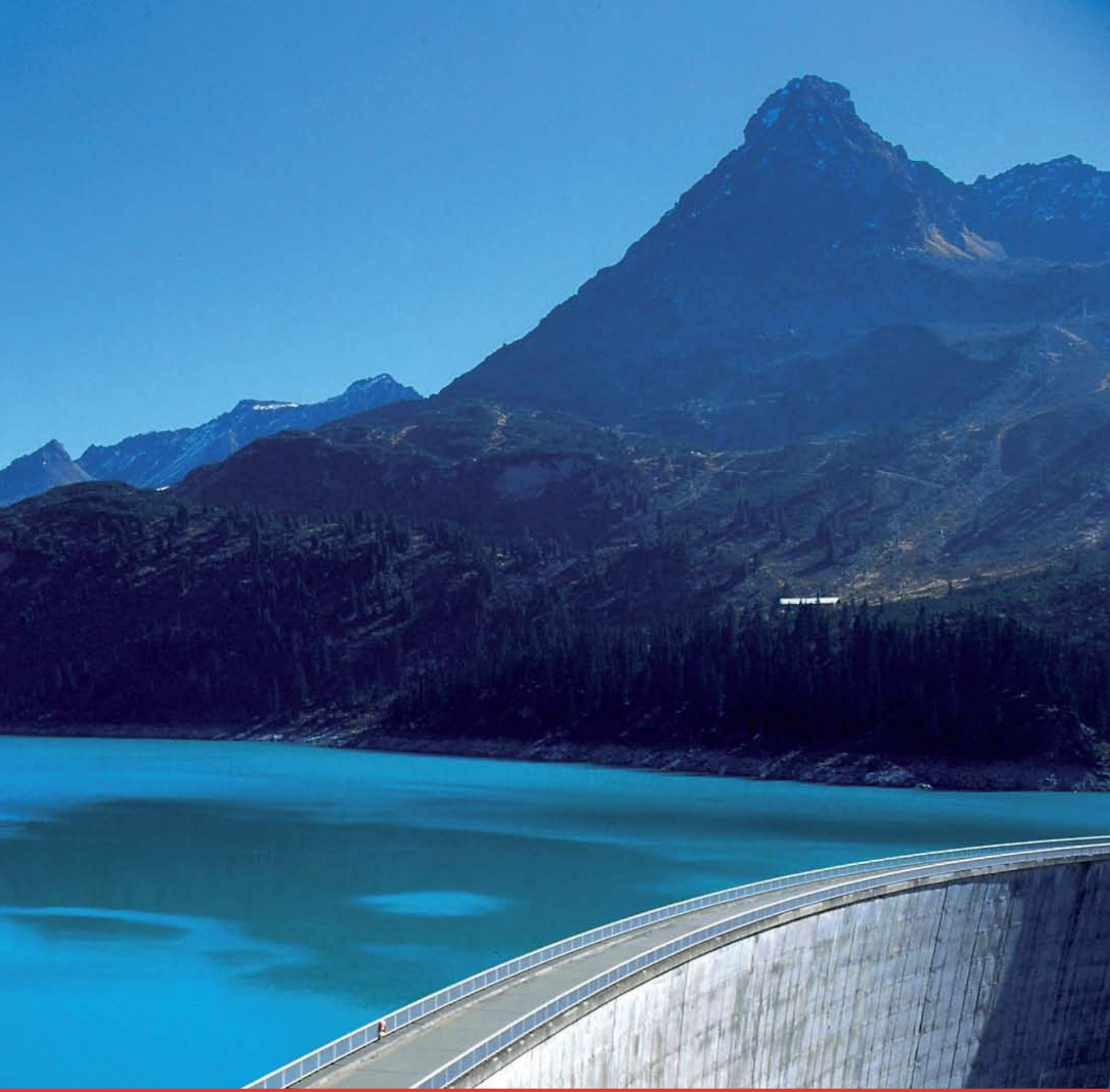

Electrical Solutions for
Power Generation



Converteam—the world leader in electrical solutions

Converteam is an engineering company providing customized solutions and systems converting electrical energy into productive performance and reversely. Our offering ranges from design only to turnkey systems, installation and commissioning, and is backed by a wide choice of services. Serving specialized segments as well as our core markets in marine, oil & gas and offshore, power generation, renewable energy and industry, our 5,000 experts and skilled workforce provide effective responses to customers around the globe.



Proven Expertise, Outstanding Performance and References

A global offer for power generation applications

Worldwide energy demand will continue to grow over the next 20 years. Safe energy supply and improved productivity in conjunction with ever-increasing availability are requirements that modern power stations must meet.

Converteam offers a broad range of electric machines and power electronics with a global sales and engineering support, plus a worldwide support and service network.

We combine a wealth of experience with innovation to deliver consistency, reliability and the latest technology. Our portfolio covers a large range of starting Static Frequency Converters (SFC) and Static Excitation Equipment (SEE) units that are used for gas turbine driven generators and large synchronous machines.

Depending on the start-up process, the SFC power is rated between 1 MW and 40 MW. SEE units are available up to a generator power of 1000 MW. Taking our lead from our customers' needs, we implement every required configuration. A powerful range of low and medium voltage variable speed drives are available for boiler feed pumps, circulation pumps, cooling water pumps, condensate pumps, exhaust and draught fans, conveyors, coal mills and other auxiliary drives. The variable speed drive solution can save up to 50% of energy consumption compared to fixed speed solutions.

Converteam offers a range of generators from 6 MW to 120 MW in different fields such as gas, steam and hydro turbines. Our generators and power electronics expertise also guarantees the best possible value for wind energy customers. The offer includes generators and converters with outputs ranging up to 8 MW. Thousands of Converteam installations are in operation worldwide. Continuous research and development safeguard the high standard of our solutions.



Compact unit - a combination of SEE and SFC

Static Frequency Converters and Static Excitation Equipment

Pumped storage power plants (PSPP) are reversible hydro power plants connecting an upper water reservoir to a lower one. The diagram below shows an example of a typical configuration of a static frequency converter (SFC) and static excitation equipment (SEE) unit for coping with grid power variation.

Pump mode and turbine mode

Pump and turbine operations alternate in pumped storage power plants. The pump turbines store energy, filling the upper reservoir when the power demand is low, typically during the night. Then they restore power to the grid to meet peak demand throughout the day. The SFC starts up the units sequentially in pump mode and launches them to the grid within a few minutes.

SFC experience

Everyday, Converteam SFCs successfully start up more than 22 GW in terms of generator power in pumped storage power plants.

Implementation in power plants

We offer solutions for any type and size of power plant. Usually, the pump turbines are equipped with synchronous or asynchronous machines. Converteam offers a broad range of static frequency converters, static excitation equipment and compact units. The compact unit is a combination of both technologies in one cabinet (see the photo on page three), with one single interface to the power plant control. A typical configuration is the use of one SFC for up to four machines and two SFCs for six machines. The SFC is implemented without G/M set modification. Converteam provides air or water cooled systems, either for indoor installation or packaged in a container for outdoor use. Depending on the power requested, the SFC operates at the rated G/M voltage or at a reduced voltage. Converteam SFCs feature the following advantages:

- The SFC system offers braking possibilities by regenerating the power to the grid.
- The G/M can be started up in synchronous condenser mode which saves water in the reservoir.
- The SFC offers the flexibility to be used for rotor balancing, bearing inspection and maintenance of the shaft.

Modern medium voltage inverter systems along with a doubly-fed induction machine are used to design variable speed pumped storage power plants with a higher flexibility and efficiency.

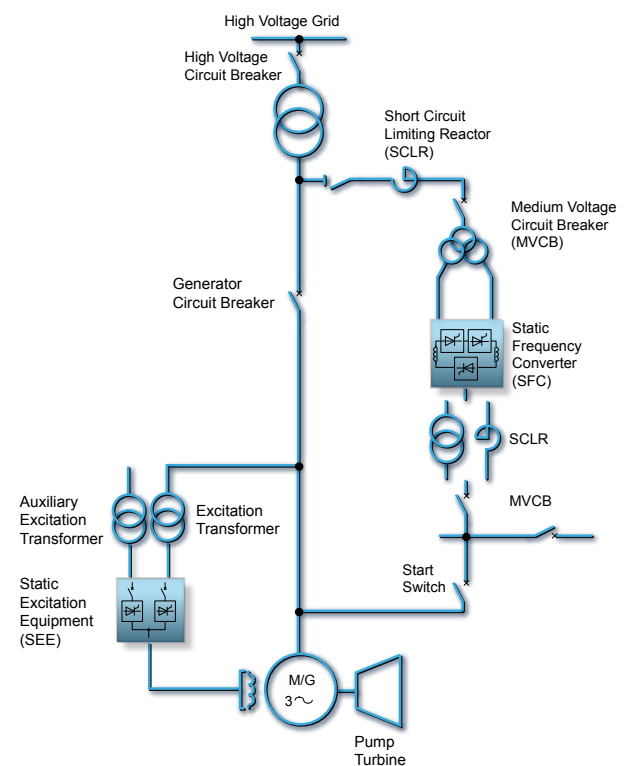

Goldisthal pumped storage power plant

The 1060 megawatt PSPP at Goldisthal is one of the most advanced hydroelectric power plants in the world. It is equipped with four rotating machines of 300 MW each. Converteam supplied the following systems:

- Two 100 MVA converters for the variable speed asynchronous machines
- Two SFCs with 18 kV / 40 MW for starting up all machines
- Two static excitation equipment (SEE) units for the synchronous machines

for Pumped Storage Power Plants, Gas Turbines and Combined Cycles



Soft gas turbine starting

Converteam static frequency converters enable a soft starting system to be implemented for gas turbines with generators running as motors. Typically, one SFC supplies one machine. However, if the turning gear function is not required, two SFCs can support up to six machines. A high level of availability is provided by a cross-start function within the SFCs.

Features and benefits

- Shaft speed control and the adjustable acceleration function enhance process performance
- Using the SFC as a turning gear facilitates shaft line balancing and cooling
- SFCs operate the gas turbine during maintenance for washing and purging purposes
- Powerful industrial PC with a 15" touch screen provides optimum user friendliness for local or remote monitoring, controlling, diagnostics and network integration via fieldbus
- Extended factory tests for shortest possible commissioning time and maximum reliability

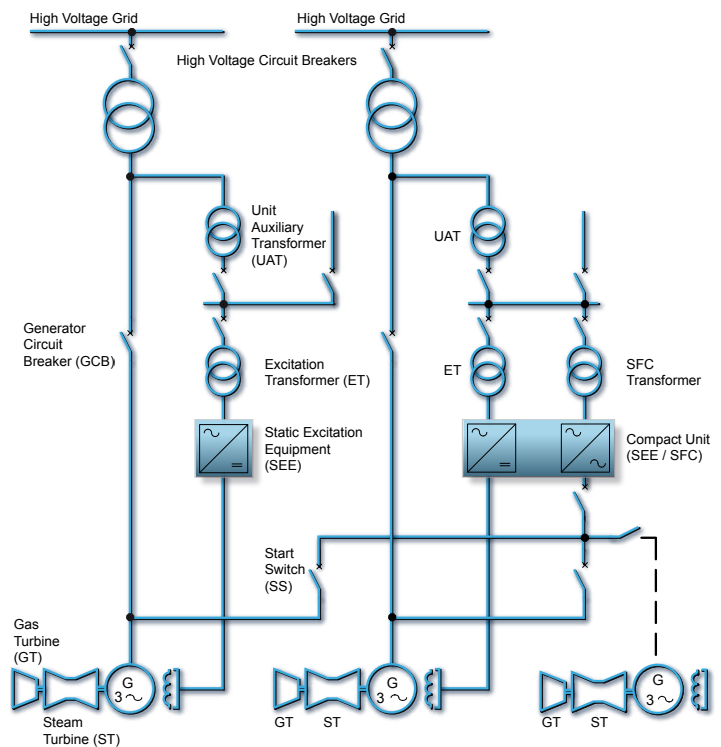

Static Frequency Converters and Static Excitation Equipment

Main applications

- Pumped-storage power plants
- Gas turbine power plants
- Synchronous condensers
- Feed pumps and fans



Compact unit – 15.5 MW SFC and 2000 A SEE for maximum power and reliability

Static Frequency Converter (SFC)			Static Excitation Equipment		
Output Power (MW)	Max. Voltage Input/Output	Dimensions SFC (w x d x h) mm	Continuous Current (A)	Max. Voltage Input (V)	Dimensions (w x d x h) mm
1.9	1400	1200x1000x2200	1200	780	2100x1000x2200
2.9	1400	1800x1000x2200	1350	660	2100x1000x2200
4.0	1800	1800x1000x2200	1550	540	2100x1000x2200
5.0	2000	1800x1000x2200	1650	780	2100x1000x2200
9.0	2800	4200x1200x2200	1850	660	2100x1000x2200
15.5	3500	4200x1200x2200	2000	780	2100x1000x2200
Compact Unit (SFC+SEE)			2400	660	2700x1000x2200
Compact units are based on proven power electronics modules. The design features can be arranged according to the individual plant requirements. Example 1: The compact unit (see above) comprises a 15.5 MW SFC and a 2000 A SEE. Example 2: The compact unit (see page 3) comprises a 5 MW SFC and a 1550 A SEE and saves a space of 600 mm.			2800	540	2700x1000x2200
			3200	780	3300x1000x2200
			3600	660	3300x1000x2200
			4200	540	3300x1000x2200
			4400	780	3900x1000x2200
			4500	960	5100x1000x2200
			4900	660	3900x1000x2200
			8000	780	6300x1600x2200

Technical data and dimensions given for basic products are subject to change without notice. Please contact Convertteam for details.

Design Features, Customer Benefits and Valuable Savings



Static frequency converters (SFC)

Nowadays SFC technology is the state-of-the-art starting technology for main generators, which often have to be started and run up quickly at short notice. In applications with several generators, a cross-over logic is available to start up the generators with one SFC. We offer a standard range of air cooled converters from 1.9 MW to 15.5 MW and tailor-made water cooled solutions for higher power ratings. The main advantages are a high degree of design flexibility as well as the high-performance control platform at the heart of the system. The control part is based on a modular multiprocessor system with a real-time multitasking operating system. It features hardware and software modules arranged according to the required I/O configuration and process needs. All major field-bus protocols are supported for communication with the power plant control.

Static excitation equipment (SEE)

Converteam belongs to the world's leading manufacturers of SEE units, with an installed base of more than 700 systems in the field. The Semipol static excitation system provides the necessary field current for synchronous generators from 20 MW to 1000 MW. Standard Semipol units are available up to 8000 A DC. Typical features for SEE units are: redundant control, redundant fans, redundant thyristor bridges (n-1), integrated power system stabilizer, control limiters for the field and stator current under excitation, V/f, etc. and a user-friendly customer interface for simple operation, monitoring, diagnostics and maintenance.

SFC experience

Everyday, Converteam SFCs successfully start up more than 60 GW in terms of generator power in gas turbine power plants.

(SEE)	
Max Ceiling Voltage (V)	Max Ceiling Current (A)
1000	1800
850	2030
700	2330
1000	2480
850	2780
1000	3000
850	3600
700	4200
1000	4800
850	5400
700	6300
1000	6600
1250	6750
850	7350
1000	12000

Compact unit

The most space and cost saving design is the combination of a static excitation equipment unit and a static frequency converter in one system, either for indoor use or mounted in a container for outdoor use. The design features a high power density and can be arranged according to the individual plant requirements. More than 400 compact units are in operation worldwide.

Powerful Low and Medium Voltage Drives

Converteam is a well established supplier of variable speed drive systems for the power generation market and for robust industry applications. We offer a low voltage drive range up to 2200 kW and a medium voltage drive range up to 33 MW. Our drives can substantially improve the quality and efficiency of your processes.



Medium voltage drive MV7000

MV7000 drives cover the medium and high power range up to 33 MW at two motor voltages, 3.3 and 6.6 kV. With efficiency of up to 99%, they can feed both induction and synchronous machines with high performance vector control, across all speed ranges. The drives are water cooled PWM voltage source inverters. Easy front access, a low component count and a fuseless protection system provide maximum reliability. The MV7000 drives feature different options such as regenerative front ends, dynamic braking choppers and connection to a DC link, so that the drive can be configured to suit all applications.

Low harmonics and energy optimization

Featuring as standard a 12-pulse (or 24-pulse) diode front end, fed by a 2 (or 4) phase-shifted secondary

winding transformer, the harmonics injected into the network are very low. The drive complies with international standards for voltage and current harmonic distortion, without any harmonic filters or VAR compensation equipment. For reversing applications with frequent braking, a PWM active front end enables the regeneration of energy to the network. Additionally, the active front end gives a unity power factor and a sinusoidal input with negligible harmonics.

Low voltage drive LV7000

LV7000 drives cover the low voltage power range up to 2200 kW at 400 V to 690 V. The key design feature is the software modularity. Two types of control are available – standard sensorless vector control and closed loop flux vector control for more demanding applications.

Converter Technology for Variable Speed Applications

Many applications benefit from variable speed drives which facilitate operation, improve processes, save energy and increase reliability. Variable speed drives are used as starting systems but also as variable speed drives for pumps, compressors and fans.



Power station auxiliary drives

In thermal power stations dedicated to grid frequency stabilization, drives are used to run the main boiler feed pumps at variable speed, allowing the output power to be adjusted in a very short time. Furthermore, drives run cooling water pumps, circulation pumps and condensate pumps. In coal thermal power stations, drives are used to run conveyors, coal mills and exhaust and/or final draught fans, in order to adjust the output power. Impressive benefits are energy savings and significantly reduced gas emissions.

Other applications

- SFCs allow for the starting of synchronous condensers providing reactive power to HV DC links or sustaining HV overhead lines over long distances.
- Large compressors in LNG liquefaction plants – SFCs are used to start up gas turbines in sequence and then act as helpers to stabilize the train speed. For the helper function, power is exchanged through the SFC between the grid on the one hand and the two synchronous helper motors which are coupled together on the other hand. Thus, the role of the SFC is to keep the speed constant whatever the load condition of the compressor train.
- Voltage source inverters are also used to balance out different loads between the three-phase 50 Hz public grid and the two-phase 16.7 Hz traction power grid.
- SFCs start high power short-circuit generators in HV testing laboratories. They re-speed up the short-circuit generator between two successive short-circuits, and thus, allow the laboratory to perform tests in repetitive speed conditions.

Turbine Driven Generators, HTS Generators and Motors

Converteam offers an extensive range of synchronous generators, driven by gas, steam, water, wind turbines or diesel generators as well as motors for auxiliary systems, suitable for power plants of all types.

Generators

Every Converteam generator is designed according to the latest design and manufacturing techniques. The high-quality Resivac™ Vacuum Pressure Impregnation (VPI) insulation technology guarantees reliability and safety in operation. The versatility of our range allows for many different cooling system options to suit our customers' preferences. Unless provided with heat exchangers, machines have ventilation inlets and outlets protected to IP23. Totally enclosed arrangements can be supplied, incorporating air-to-air (CACA/TEAC) or air-to-water (CACW/TEWAC) heat exchangers, or hydrogen cooling to fit various application requirements. Converteam can tailor and customize our product range to meet your mechanical, electrical and site requirements.

Wind generators

Converteam has developed a range of power dense permanent magnet generators (PMG) for wind turbine applications.

Our offer includes:

- Direct drive (DD PMGs - the Zeus Range) that eliminates the requirement for a gearbox and also
- Intermediate speed (partially geared or hybrid) that reduces the generator mass.

HTS hydro generators

HTS hydro generators can be used for variable speed applications by introducing a power converter, as well as for fixed speed operations. The benefits of HTS technology applied to a motor or a generator are:

- Reduced size and weight (by 3 or 4 times)
- Improved performance with almost zero losses
- Significantly reduced noise and vibration levels
- Dramatic reduction in maintenance work

The impressive power density of HTS machines means the gearbox can be removed and it may even be possible for the turbine rating to be increased without significant changes to the civil works. Converteam has successfully designed, manufactured and tested a 250 kW, 1500 rpm prototype and is also working on the first commercial 1.25 MW HTS hydro generator.

Synchronous and induction motor technology

Converteam offers a full range of horizontal and vertical synchronous motors up to 100 MW and induction motors up to 40 MW. Synchronous motors ranging from direct drive high torque density motors – at speeds as low as 20 rpm – to turbo-type motors for higher speed applications. In combination with a variable speed drive, induction motors can now be used in almost all applications where high reliability and robust performance is required.

	Gas & Steam Driven Turbine Generators	Diesel, Gas & Engine Driven Generators	Wind generators	Hydro Generator
Rating	2.500 kVA to 130 MVA	2.500 kVA to 45.000 kVA	Up to 8 MW	2.500 kVA to 50.000 kVA
Voltage	3.3 kV to 15 kV	3.3 kV to 20 kV	0.6 kV, 0.9 kV to 3 kV	3.3 kV to 15 kV
Frequency	50 Hz or 60 Hz	50 Hz / 60 Hz	Variable Frequency (VF)	50 Hz / 60 Hz or VF
Pole Number	2 and 4	6 to 22	Optimized	Optimized
Insulation Class	Class F			
Temperature Rise	Class F or B			

Effective Partnership and Customized Services

Converteam provides its customers with comprehensive service support, ranging from spare parts, repairs and training to long term performance-based service contracts and modernization solutions. Our global footprint includes more than 50 Regional Business Centres in 17 countries to ensure a timely response.



Close partnership

In order to meet your needs Converteam works in close partnership with you. We understand service provision as being much more than simply waiting for your call. At Converteam, we are committed to proactive management of our systems throughout their lifecycle, allowing you to plan ahead and take action to pre-empt system failures. For that purpose we offer tailor-made service agreements with a contractually agreed response time, so if service is required, our experts will be with you on site within the shortest possible time or the remote diagnostics service enables Converteam specialists to diagnose your plant and to take action to remove errors 24 hours a day anywhere in the world.

Training and maintenance

Training is given prime importance. Training sessions are conducted by experts in power electronics and control systems, either on site or in Converteam training centers. Our professional trainers coach your employers using hands on exercises with real equipment in courses tailored to your specific needs.

Expert evaluation and modernization

To help our customers to cope with the fast evolution of process performance, safety regulations and increasingly stringent environmental requirements, Converteam offers an expert evaluation service and a wide range of possible upgrades.

Customer benefits

- Service support around the clock
- Worldwide availability
- Remote diagnostics
- Spare parts management and repairs

Headquarters:

Converteam Group SAS
30, avenue Carnot
91345 Massy Cedex, France
Tel: +33 (0)1 64 53 83 00

Main offices:**Brazil**

Converteam Brasil Ltda
Av. Álvares Cabral, 1345
Bairro Lourdes, Belo Horizonte
Minas Gerais, 30170-001
Tel: +55 31 3330 5800

Canada

Converteam Inc.
845 Harrington Court
Burlington, Ontario L7N 3P3
Tel: +1 905 333 3667

China

Converteam Power Conversion (Shanghai) Co., Ltd.
29F, Building A, Lane 58,
East Xinjian Road, Minhang District
201100 Shanghai
Tel: +86 21 641 46080-8000

France

Converteam SAS
1, Square John H. Patterson
91345 Massy Cedex
Tel: +33 (0)1 77 31 20 00

Germany

Converteam GmbH
Culemeyerstrasse 1
12277 Berlin
Tel: +49 (0)30 7622-0

India

Converteam India Private Ltd.
Unit No 1003, Tower B, 10th Floor
Millennium Plaza, sector 27
Gurgaon, 122 002 Haryana
Tel: +91 124 4220 300

Norway

Drives & Controls Services Ltd.
Scandinavian Branch
Lysaker Torg 45
1326 Lysaker
Tel: +47 67 83 82 50

Russia

Converteam GmbH
Dubininskaya Str. 53, Bldg. 5, office 212
115054 Moscow
Tel: +7 499 270-27-11

Singapore

Drives & Controls Services Ltd., Singapore Branch
331 North Bridge Road #07-05
Odeon Towers
Singapore, 188720
Tel: +65 6332 0940

South Korea

Drives & Controls Services Ltd.
Korean Branch
3F, Dong Ju Bldg
1200-12, Cho Ryang-Dong, Dong-ku
Busan, 601-838
Tel: +82 51 465 9050-1

United Arab Emirates

Converteam SAS
Khalidya Road
Pearl Plaza building
P.O. Box: 42536 Abu Dhabi
Tel: +971 2 639 0846

UK

Converteam UK Ltd.
Boughton Road
Rugby, Warwickshire
CV21 1BU
Tel: +44 (0)1788 563 563

USA

Converteam Inc.
610 Epsilon Drive
Pittsburgh, PA 15238
Tel: +1 412 967 0765

www.converteam.com