

The cooling circuit provides uniform ventilation and effective cooling throughout the machine.

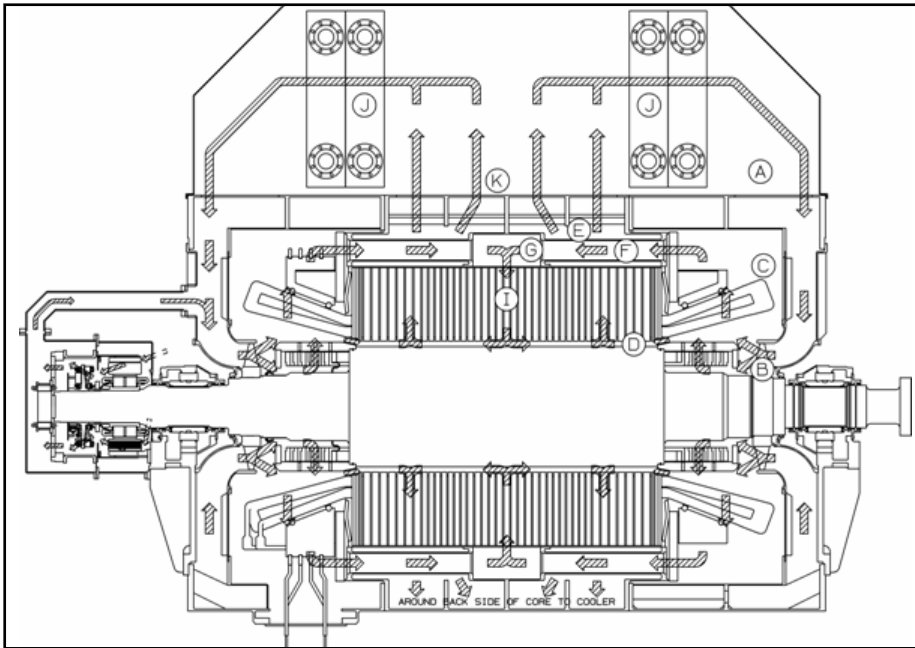

Air flow in generator with TEWAC enclosure and water air heat exchangers.

Machine Ventilation

Air is brought to the fan inlet at (A). The air passes through the fan (B), with some passing over the stator coil end turns (C), then through the air gap and stator ventilating ducts (D) into the annular space (E) behind the core. The air that passes through the stator coil end turns flows through tubes (F) to the annular portion (G) surrounding the central part of the core. This air then passes to the air gap through the core ventilating ducts (I) and is discharged through a duct on top of the frame.

Stator Ventilation

Stator winding end turns are cooled by air discharging radially for the rotor fans, and passing through the spaces between the

end turns. The stator core is uniformly cooled by air that flows from several inter-connected center chambers that receive air directly from the fans. From these center chambers the air first flows radially down to the air gap via one group of stator core ducts. These ducts are equipped with directional spacers to direct the air flow in the direction the rotor is moving. The air in this pressurized portion of the air gap also flows axially in both directions to other groups of ducts equipped with directional spacers designed to scoop air from the air gap and direct it radially through the stator core ducts. The stepped ends of the stator core facilitate easy entry of air for gap cooling that portion of the stator core.

Rotor Ventilation

Rotor ventilation slots are positioned directly under the rotor coils. Holes are pierced at regular intervals along the length of the rotor conductors. Holes in the copper are matched with the holes in the aluminum wedge to allow radial discharge of warm air from the ventilation slot.

During operation cool air is introduced under the retaining ring at each end of the rotor. Part of this air passes through the space between the rotor coil end turns and is discharged through ventilation holes in the retaining rings. The remaining part of the air enters the rotor ventilation slot.

Some of the air is radially discharged near the end of the rotor. However, because the slot below the conductors is much larger than the exit holes, it carries much more air than can discharge at one point. As a result, some of the air is discharged over the entire length of the rotor.

Enclosures

TEWAC (Totally Enclosed Water Air Cooled) generators are typically applied in dirty conditions or on machines in base load service. They are provided with a top mounted air enclosure containing two water to air heat exchangers (J), each rated for 66% (100% optional) of rated generator capacity with one cooler out of service. The hot air discharging from the duct at the top of the frame is cooled as it passes through the coolers and then returns at (A) for recirculation.

Open air cooled generators are typically provided without a top enclosure and arranged for connection to a customer provided discharge duct (K), and screened protection is provided for the air inlets (A) at each end of the machine. The ventilating air flows through the machine only one time.



Converteam Electric Machinery
800 Central Avenue NE
Minneapolis, Minnesota 55413
United States
Tel: +1 612 378 8000
Fax: +1 612 378 8051

North America Headquarters:
Converteam Inc.
Pittsburgh, Pennsylvania
Tel: +1 412 967 0765

France Tel: +33 1 77 31 20 00
Germany Tel: +49 30 76 22 0
UK Tel: +44 1788 563563
Brazil Tel: +55 31 3330 5800
China Tel: +86 21 6442 1666
India Tel: +91 44 2440 0900
Russia Tel: +7 495 225 1916